

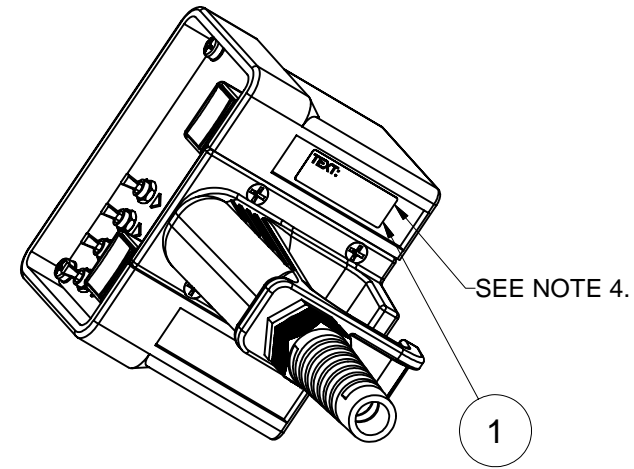

REVISION HISTORY				
ZONE	REV	DESCRIPTION	DATE	APPROVED
-	A	ORIGINAL ISSUE GMF	03 MAY 07	GMF

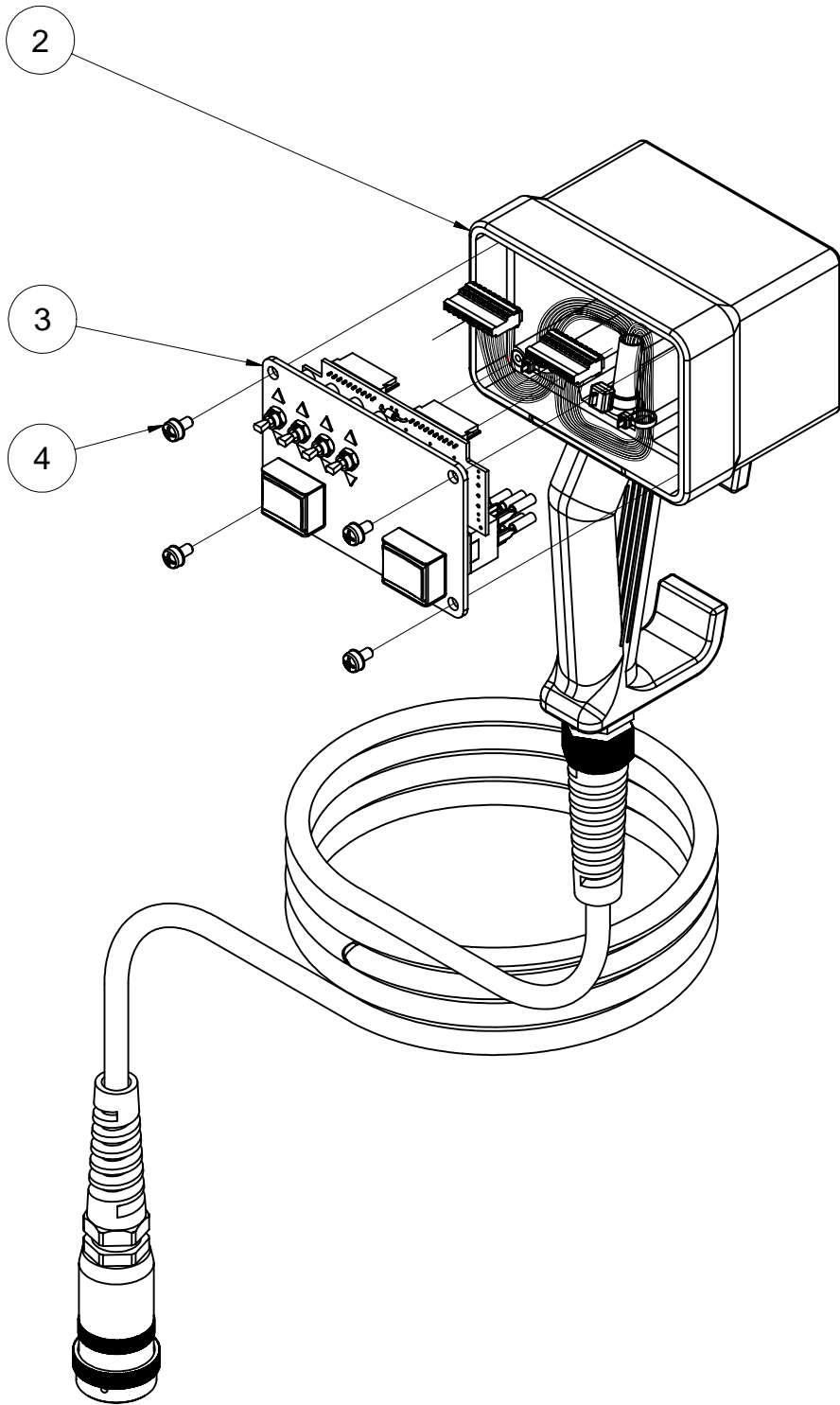
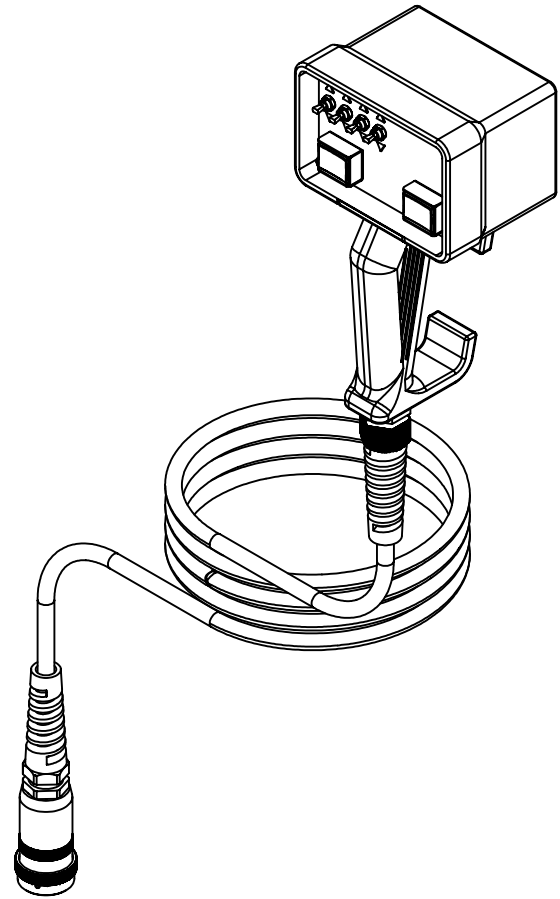
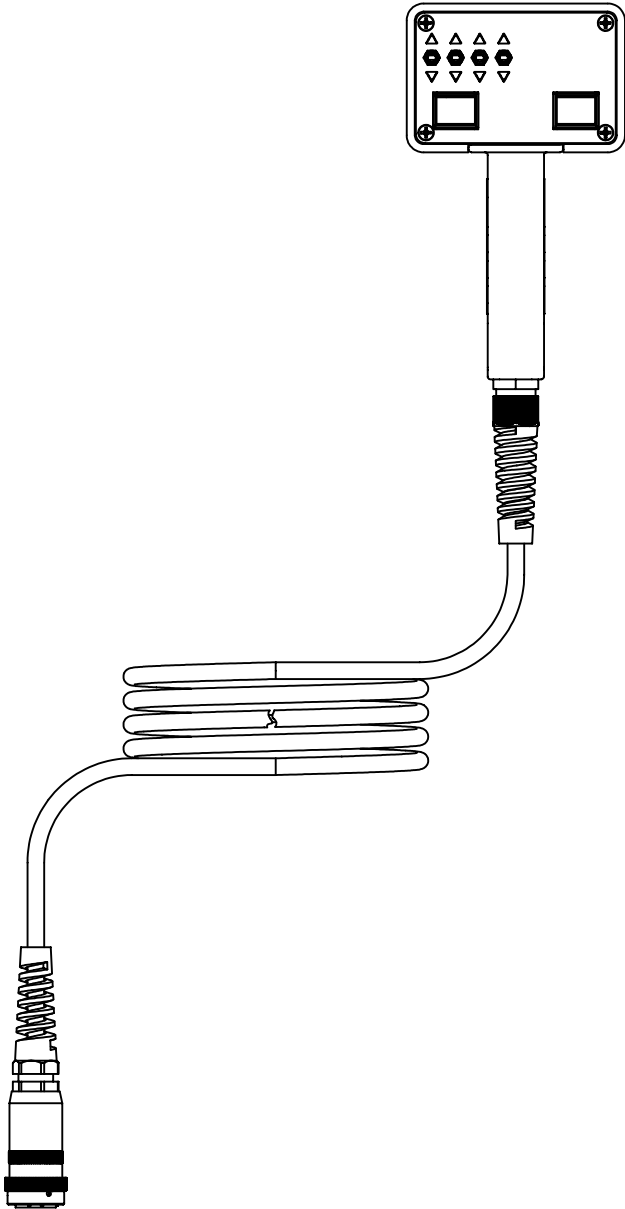

ITEM	QTY	PART NUMBER	DESCRIPTION
4	4	1900-20-02-05-004	PHMS, M4 X 8mm, Phillips, w/Captive Washer, Steel Black (Stainless)
3	1	B-16-301-0001	Face Plate Assembly, Remote, Switch Card, 4 Channel
2	1	B-17-001-0001	Enclosure, Remote Hand Held, Small, Yellow, 10' Tail
1	1	3500-02-03-00-002	Custom Label, Printable, B435/ Silver, TLS, 1.5" X .5", Y93431, 500pc Roll

PARTS LIST											
motion laboratories		TITLE		DRAWN BY		DATE DRAWN		SIZE		DRAWING NUMBER	
520 FURNACE DOCK ROAD CORTLANDT MANOR, NY 10567 (514) 789-8877		Remote Hand Held, 4 Channel, Yellow, 10' Tail		GMF		8/1/2005		C		A-16-301-0001	
				CHECKED BY		DATE CHECKED		SCALE		SHT	
								3/4		1 OF 2	
				MODEL FILENAME & PATH							
				M:\Assemblies\A-16-301-0001.lam							



 520 FURNACE DOCK ROAD CORTLANDT MANOR, NY 10567 (514) 789-8877	TITLE Remote Hand Held, 4 Channel, Yellow, 10' Tail		DRAWN BY GMF	DATE DRAWN 8/1/2005	SIZE C	DRAWING NUMBER A-16-301-0001	REV A
			CHECKED BY	DATE CHECKED			
			MODEL FILENAME & PATH M:\Assemblies\A-16-301-0001.iam		SCALE	SH1 2 OF 2	