

ZONEREV		DESCRIPTION		DATE	APPROVED
-	A	ORIGINAL ISSUE. GMF		09 MAY 07	GMF

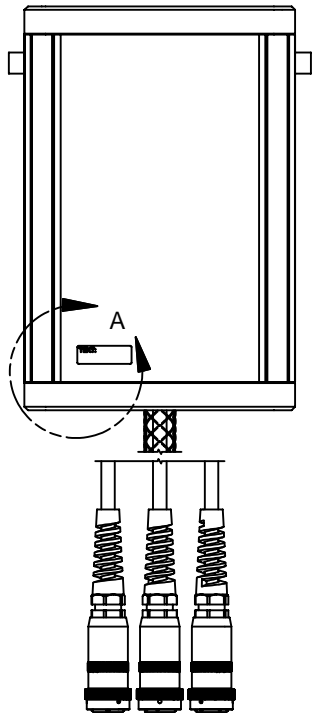

SEE NOTE 4.

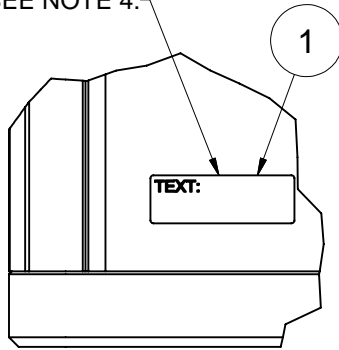

DETAIL A  
SCALE 1 : 1

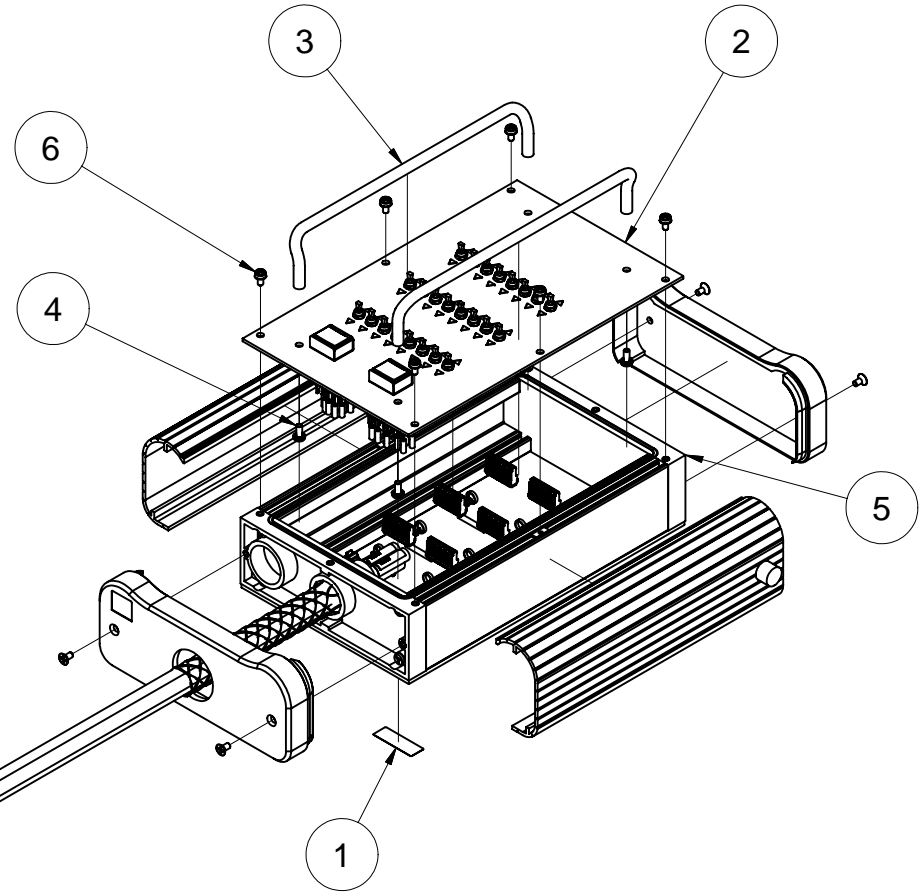

6	6	1900-20-02-05-004	PHMS, M4 X 8mm, Phillips, w/Captive Washer, Steel Black (Stainless)
5	1	B-17-002-0003	Enclosure, Remote Hand Held, Large, 5' Tail, 24 Channel
4	4	1900-03-02-05-014	SCREW, 8-32 X 3/8" PH W/LW BLACK ZINC
3	2	1900-03-08-08-002	Handle, 8-32 Tube, 10" X 1.75", Yellow, Offset
2	1	B-16-302-0003	Face Plate Assembly, Remote, Switch Card, 24 Channel
1	1	3500-02-03-00-002	Custom Label, Printable, B435/ Silver, TLS, 1.5" X .5", Y93431, 500pc Roll

ITEM	QTY	PART NUMBER	DESCRIPTION
PARTS LIST			
<b>motion laboratories</b> <small>520 FURNACE DOCK ROAD CORTLANDT MANOR, NY 10567 (914) 789-8877</small>			TITLE Remote Hand Held, 24Channel, Yellow, 5' Tail
DRAWN BY GMF		DATE DRAWN 9/9/2005	SIZE C
CHECKED BY		DATE CHECKED	DRAWING NUMBER A-16-302-0003
MODEL FILENAME & PATH M:\Assemblies\A-16-302-0003.lam			SCALE 3/8
			SHEET 1 OF 2

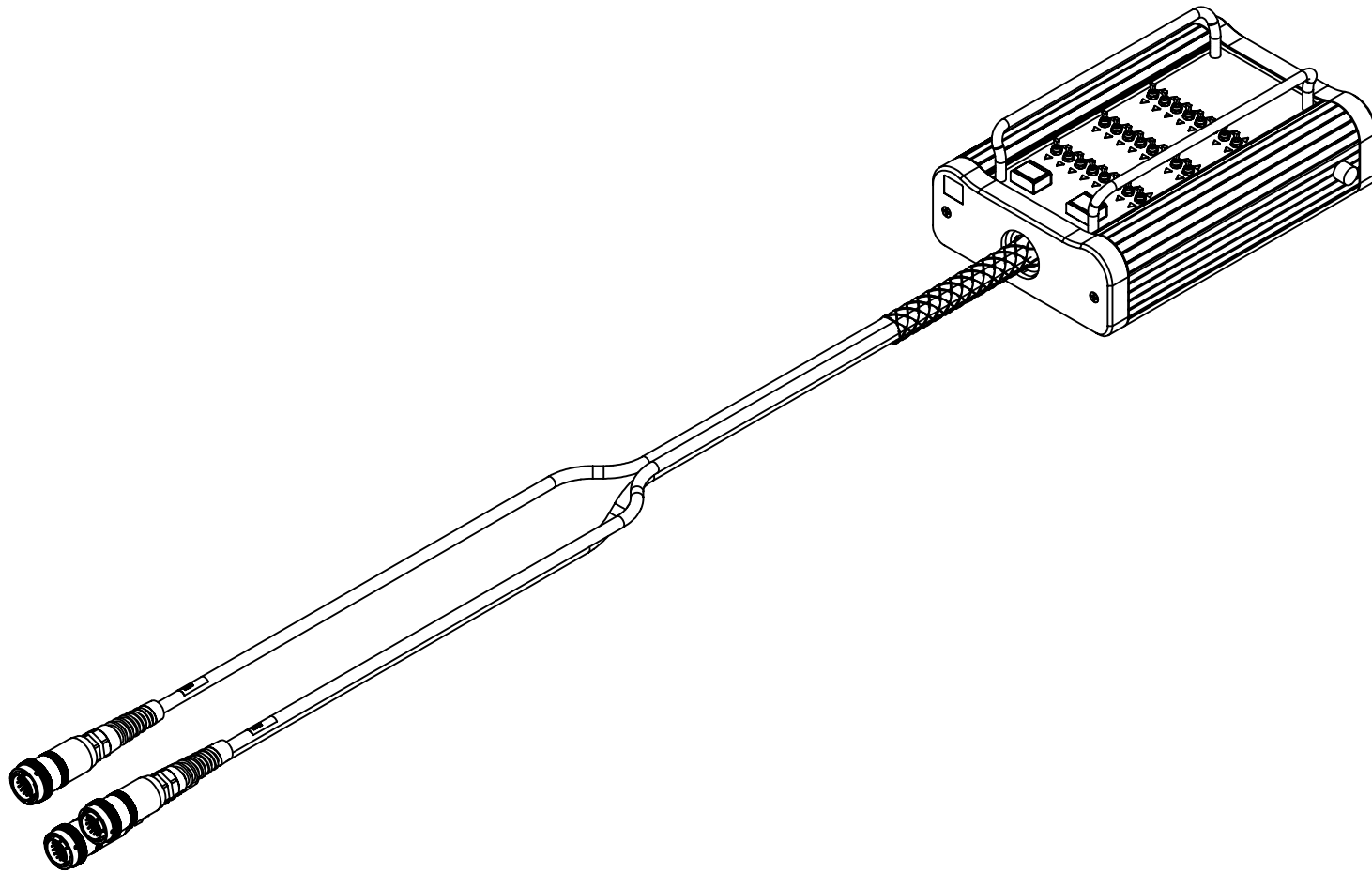

<b><i>motion laboratories</i></b> <small>520 FURNACE DOCK ROAD CORTLANDT MANOR, NY 10567 (514) 789-8877</small>	<b>TITLE</b> Remote Hand Held, 24Channel, Yellow, 5' Tail		<small>DRAWN BY</small> GMF	<small>DATE DRAWN</small> 9/9/2005	<small>SIZE</small> C	<small>DRAWING NUMBER</small> A-16-302-0003	<small>REV</small> A
	<small>CHECKED BY</small>	<small>DATE CHECKED</small>	<small>MODEL FILENAME &amp; PATH</small> M:\Assemblies\A-16-302-0003.iam		<small>SCALE</small>	<small>SHT</small> 2 OF 2	