

REVISION HISTORY			
REV	DESCRIPTION	DATE	CHECKED
1	RELEASED TO PRODUCTION. DC 7/11/14		

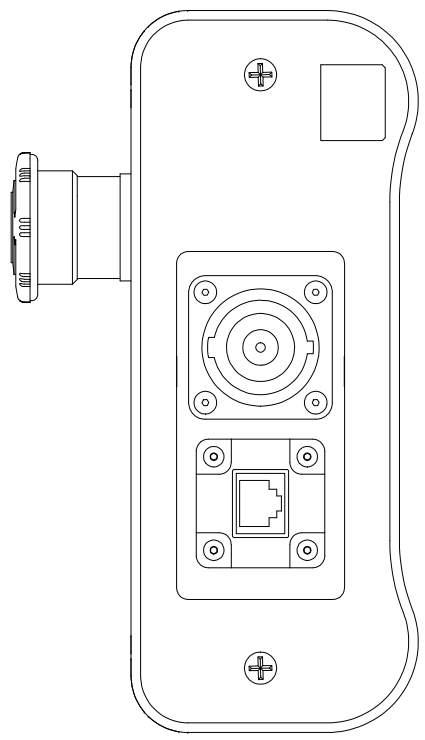
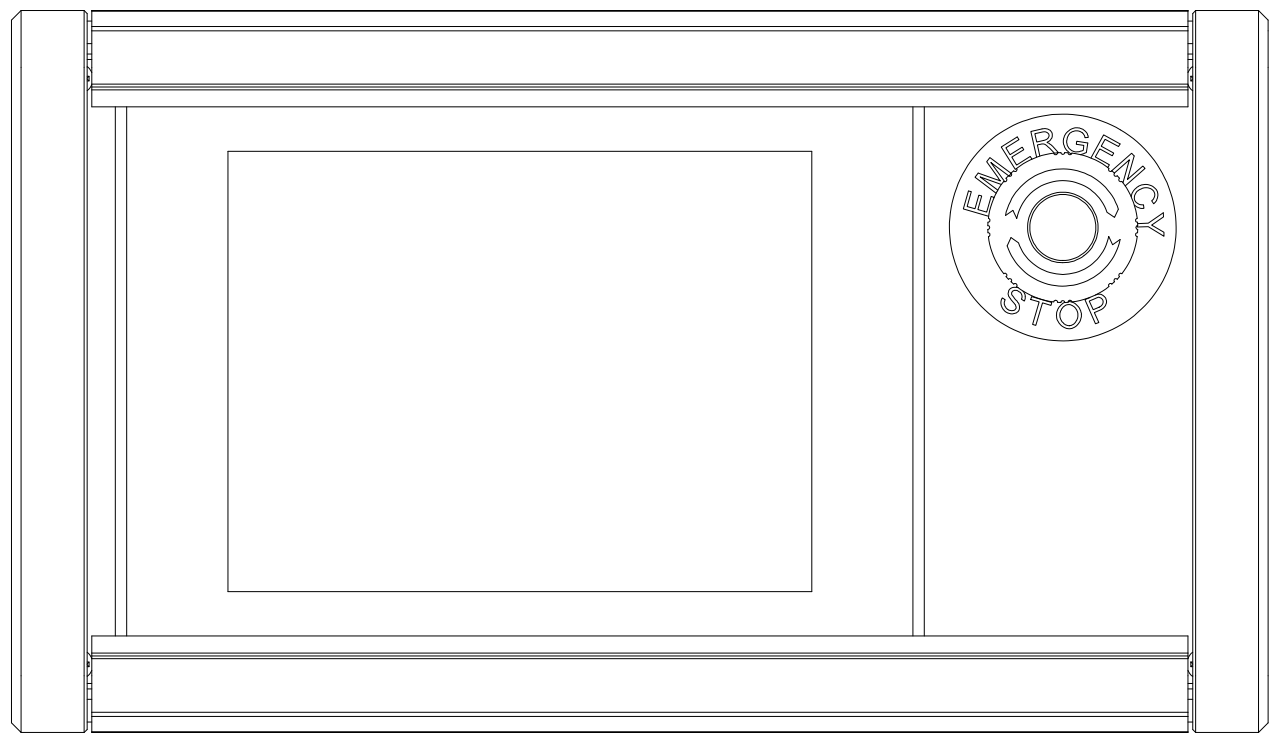
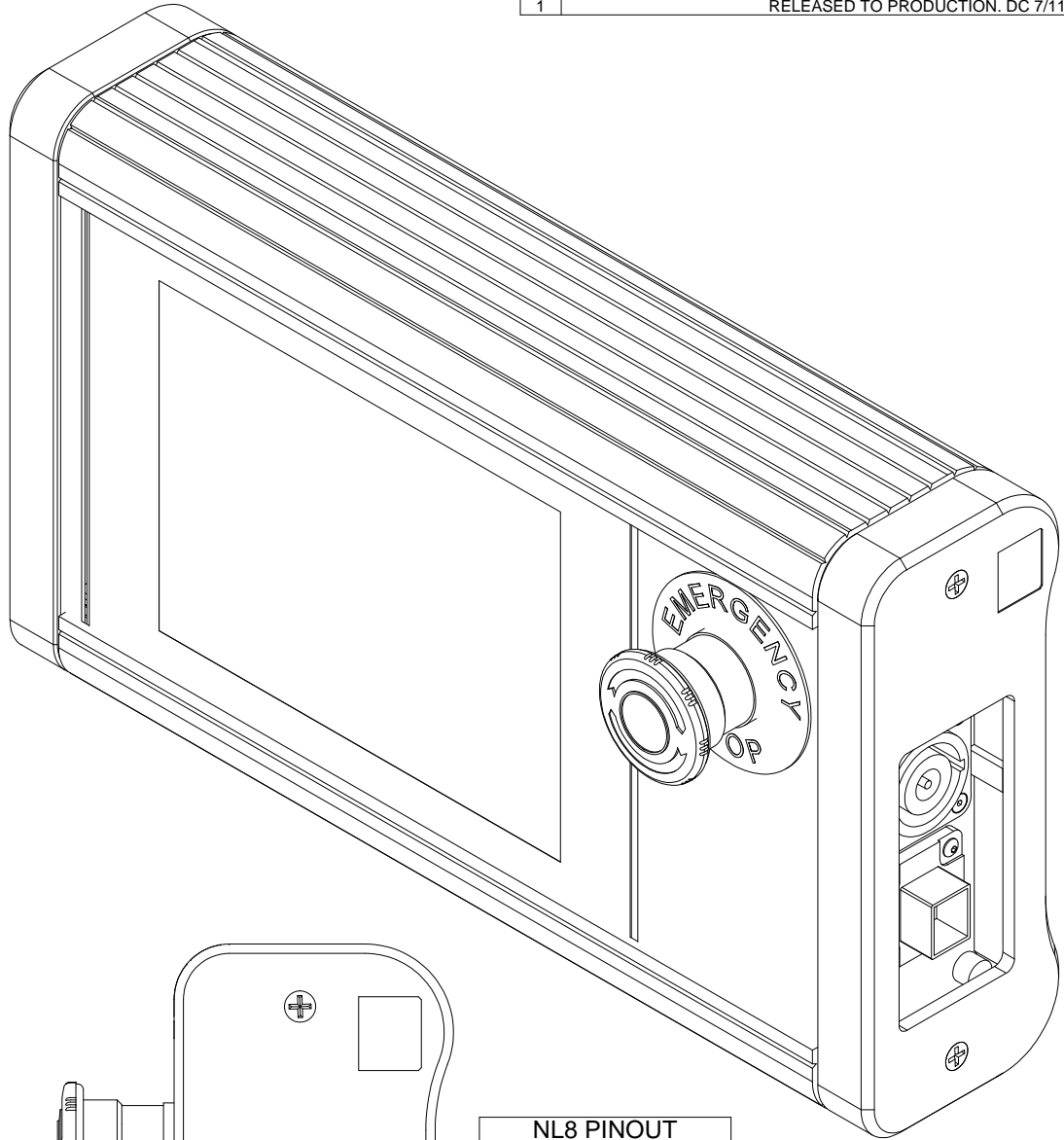

NL8 PINOUT	
PIN	FUNCTION
1+	E-STOP 1A
1-	E-STOP 1B
2+	E-STOP 2A
2-	E-STOP 2B
3+	24VDC+
3-	0VDC
4+	GROUND
4-	UNUSED

 <small>Copyright © 2014 Motion Laboratories, Inc. All Rights Reserved. This document is the exclusive, confidential property of Motion Laboratories, Inc. and shall not be reproduced, copied or used for any purpose whatsoever, unless and strictly to the extent such is expressly authorized by Motion Laboratories, Inc. in writing.</small>	motionlaboratories 520 Furnace Dock Road Cortlandt Manor, NY 10567	TITLE The Warden PLC Control System, Touch-Screen Operating System, HMI 7.5" with Enclosure, E-Stop	DRAWN BY DC	DATE DRAWN 5/20/2014	SIZE D	SALES DRAWING NUMBER A-17-005-0008	REV A
	<small>MODEL FILENAME & PATH</small> N:\Blocks\Assemblies\A-17-005-0008.sdm		<small>SCALE</small> NTS	<small>SHEET</small> 1	<small>OF</small> 1		