

REVISION HISTORY				
ZONE	REV	DESCRIPTION	DATE	APPROVED
-	A	ORIGINAL ISSUE	GMF	03 MAY 07
				GMF

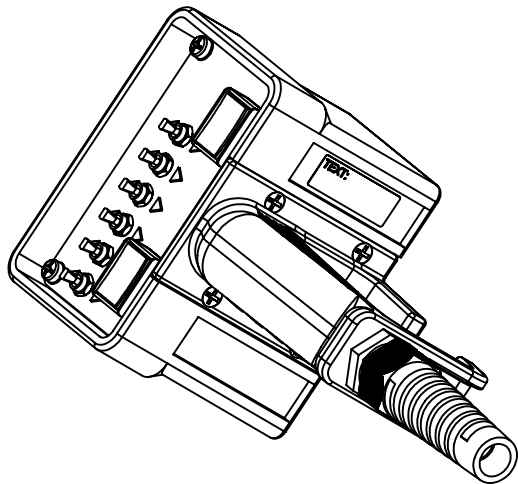

ITEM	QTY	PART NUMBER	DESCRIPTION
4	4	1900-20-02-05-004	PHMS, M4 X 8mm, Phillips, w/Captive Washer, Steel Black (Stainless)
3	1	B-16-301-0002	Face Plate Assembly, Remote, Switch Card, 6 Channel
2	1	B-17-001-0001	Enclosure, Remote Hand Held, Small, Yellow, 10' Tail
1	1	3500-02-03-00-002	Custom Label, Printable, B435/ Silver, TLS, 1.5" X .5", Y93431, 500pc Roll

PARTS LIST				
DRAWN BY	DATE DRAWN	SIZE	DRAWING NUMBER	REV
GMF	8/1/2005	C	A-16-301-0002	A
CHECKED BY	DATE CHECKED	MODEL FILENAME & PATH	SCALE	SHT
		M:\Assemblies\A-16-301-0002.lam		1 OF 2

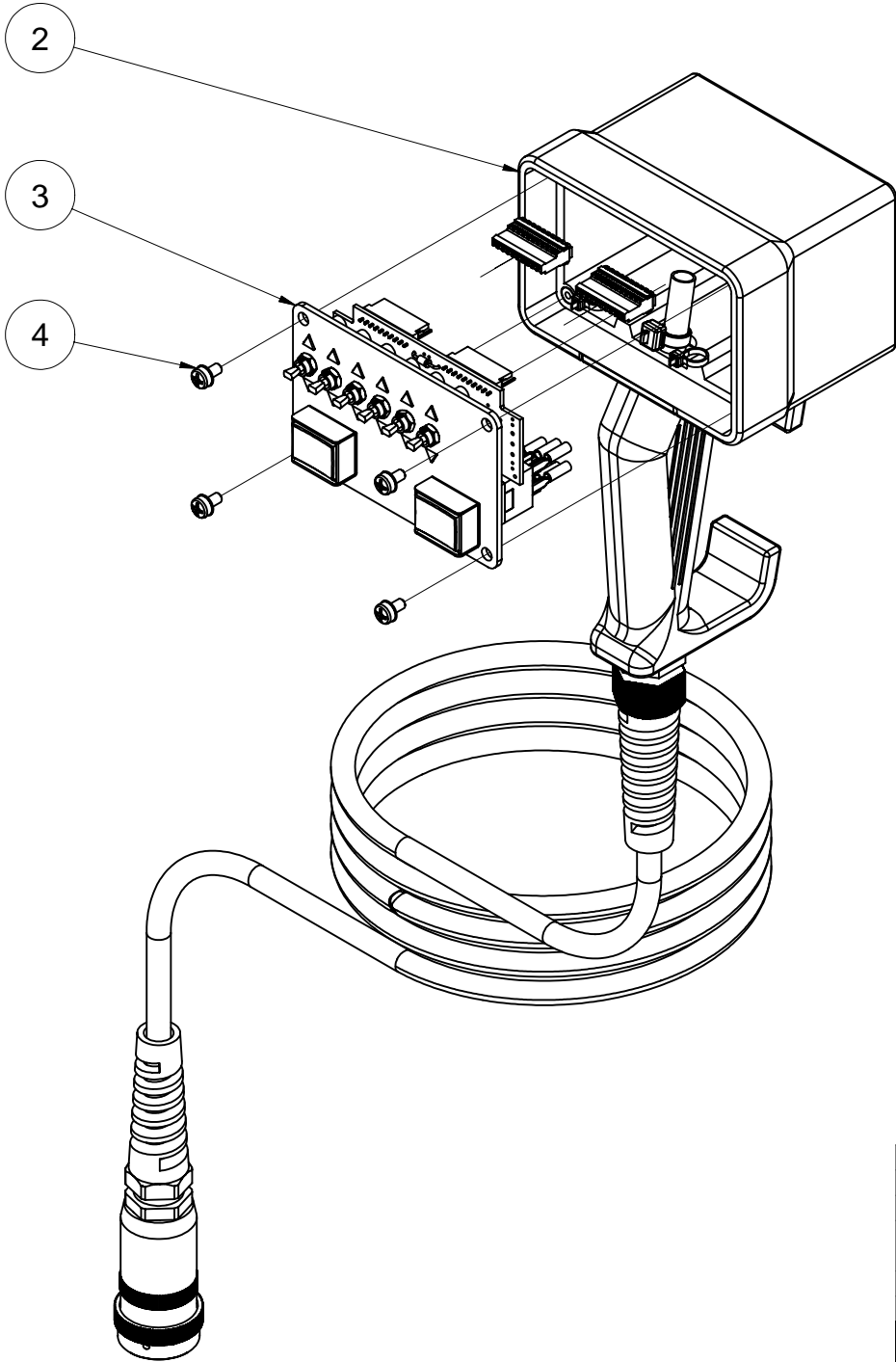

motion laboratories
 520 Furnace Dock Road Cortlandt Manor, NY 10567

 COPYRIGHT © 2005 Motion Laboratories, Inc. All Rights Reserved. THIS DOCUMENT IS THE EXCLUSIVE
 CONFIDENTIAL PROPERTY OF MOTION LABORATORIES, INC. AND IT SHALL NOT BE
 REPRODUCED, COPIED, OR USED FOR ANY PURPOSE WHATSOEVER, UNLESS AND IN EXACTLY TO
 THE EXTENT SUCH IS EXPRESSLY AUTHORIZED BY MOTION LABORATORIES, INC. IN WRITING.

TITLE
 Remote Hand Held, 6 Channel,
 Yellow, 10' Tail

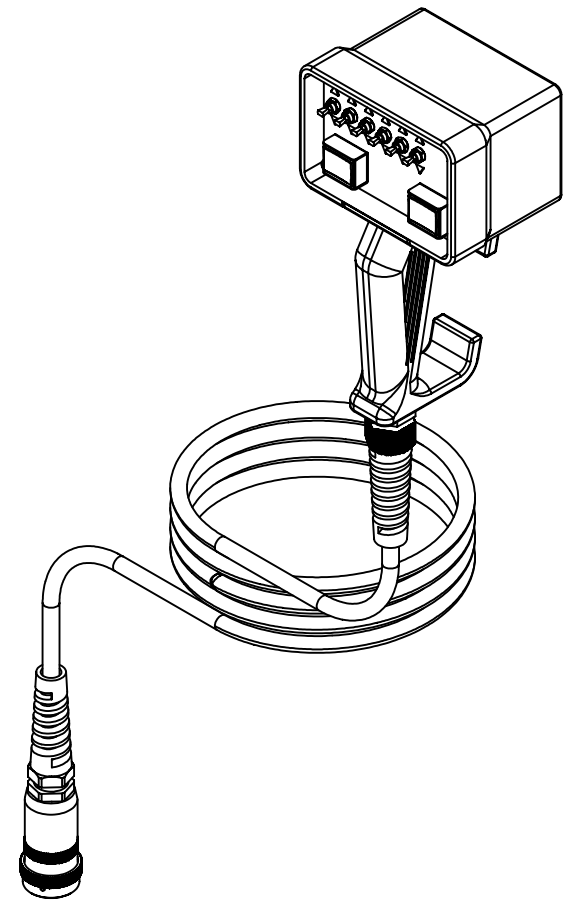
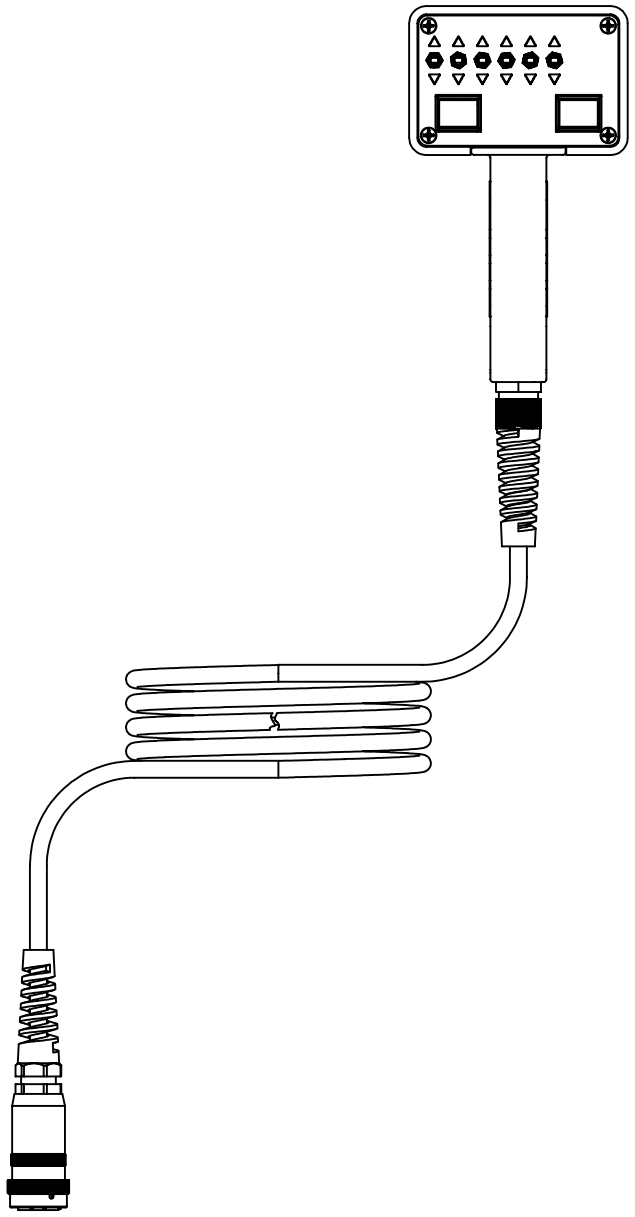
DRAWN BY: GMF
 DATE DRAWN: 8/1/2005
 SIZE: C
 DRAWING NUMBER: A-16-301-0002
 REV: A
 CHECKED BY: [blank]
 DATE CHECKED: [blank]
 MODEL FILENAME & PATH: M:\Assemblies\A-16-301-0002.lam
 SCALE: [blank]
 SHT: 1 OF 2



 <small>Copyright © 2005, Motion Laboratories, Inc. All Rights Reserved. This document is the intellectual property of Motion Laboratories, Inc. and it shall not be reproduced, copied, or used for any purpose whatsoever, unless and insofar as the extent, such as expressly authorized by Motion Laboratories, Inc. in writing.</small>	TITLE Remote Hand Held, 6 Channel, Yellow, 10' Tail	DRAWN BY SMF	DATE DRAWN 8/1/2005	SIZE C	DRAWING NUMBER A-16-301-0002	REV A
		CHECKED BY DATE CHECKED	MODEL FILENAME & PATH M:\Assemblies\A-16-301-0002.lam	SCALE SHT 2 OF 2		