

ZONEREV		DESCRIPTION	DATE	APPROVED
-	A	ORIGINAL ISSUE. GMF	09 MAY 07	GMF

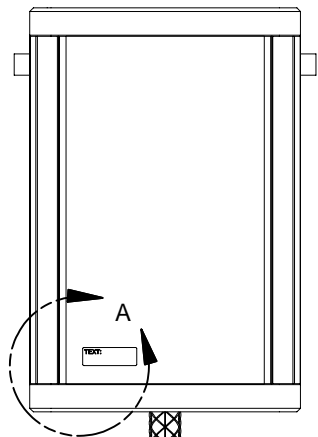

SEE NOTE 4.

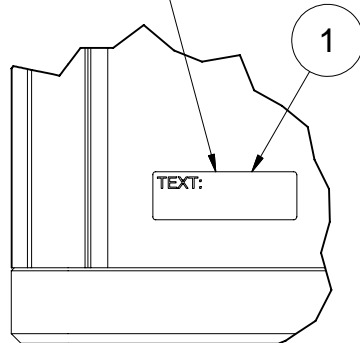

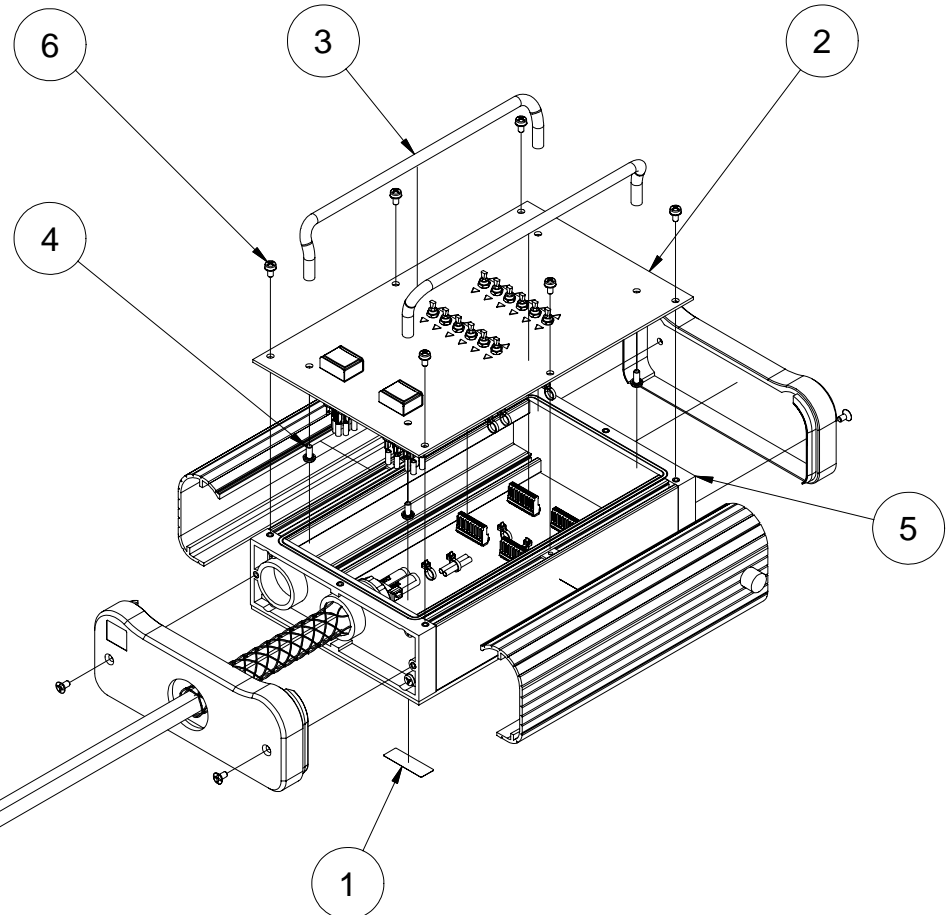
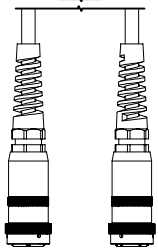

DETAIL A
SCALE 1 : 1

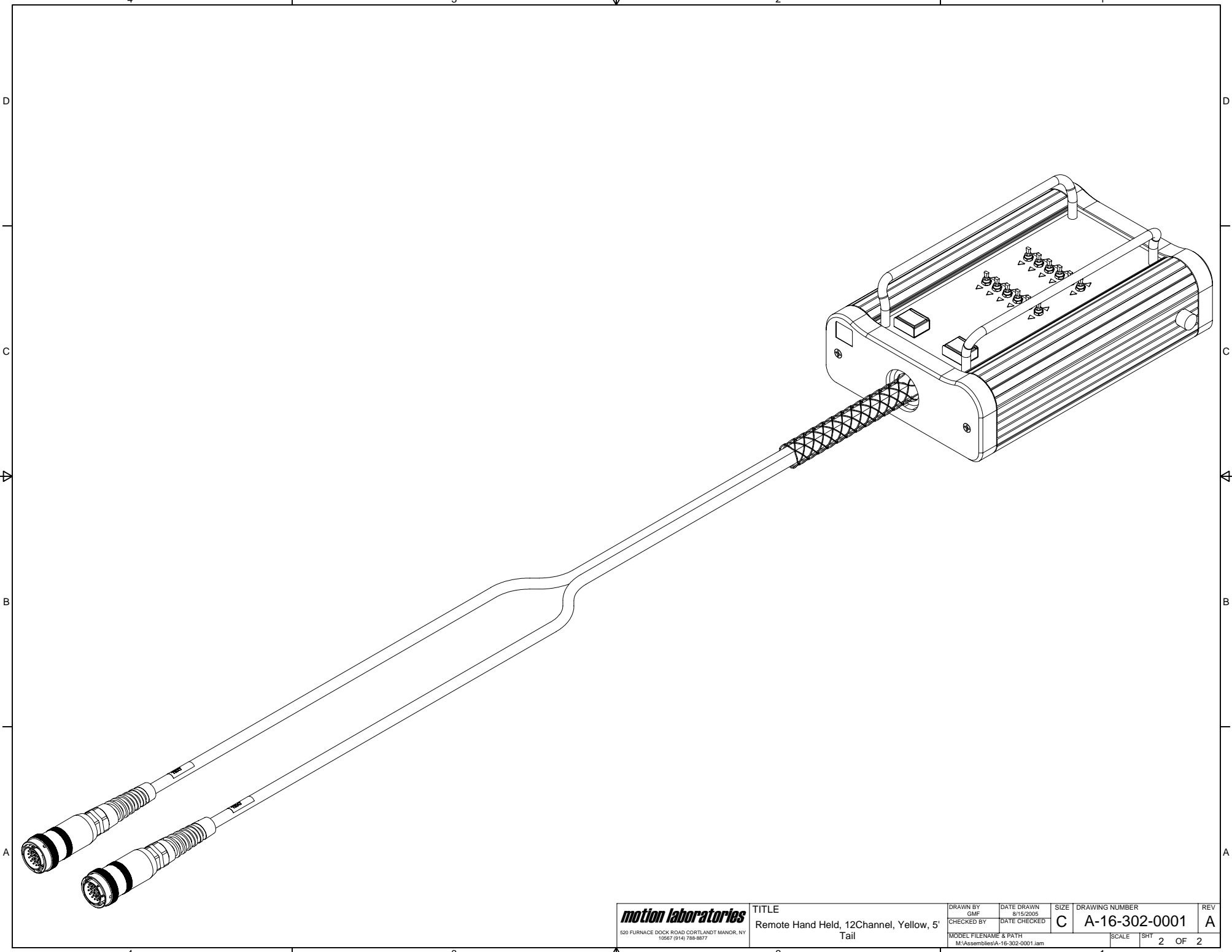

6	6	1900-20-02-05-004	PHMS, M4 X 8mm, Phillips, w/Captive Washer, Steel Black (Stainless)
5	1	B-17-002-0001	Enclosure, Remote Hand Held, Large, 5' Tail, 12 Channel
4	4	1900-03-02-05-014	SCREW, 8-32 X 3/8" PH W/LW BLACK ZINC
3	2	1900-03-08-08-002	Handle, 8-32 Tube, 10" X 1.75", Yellow, Offset
2	1	B-16-302-0001	Face Plate Assembly, Remote, Switch Card, 12 Channel
1	1	3500-02-03-00-002	Custom Label, Printable, B435/ Silver, TLS, 1.5" X .5", Y93431, 500pc Roll

ITEM	QTY	PART NUMBER	DESCRIPTION
PARTS LIST			
		TITLE Remote Hand Held, 12Channel, Yellow, 5' Tail	
<small>520 FURNACE DOCK ROAD CORTLANDT MANOR, NY 10567 (814) 788-8877</small>		<small>DRAWN BY</small> GMF	<small>DATE DRAWN</small> 8/15/2005
		<small>CHECKED BY</small>	<small>DATE CHECKED</small>
		<small>MODEL FILENAME & PATH</small> M:\Assemblies\A-16-302-0001.lam	<small>SIZE</small> C
		<small>SCALE</small> 3/8	<small>DRAWING NUMBER</small> A-16-302-0001
		<small>SHT</small> 1	<small>REV</small> A
		<small>OF</small> 2	



 520 FURNACE DOCK ROAD CORTLANDT MANOR, NY 10567 (514) 789-8877		TITLE Remote Hand Held, 12Channel, Yellow, 5' Tail		DRAWN BY GMF	DATE DRAWN 8/15/2005	SIZE C	DRAWING NUMBER A-16-302-0001	REV A
MODEL FILENAME & PATH M:\Assemblies\A-16-302-0001.iam		CHECKED BY	DATE CHECKED	SCALE	SH1 2	OF 2		