

| REVISION HISTORY |     |                     |           |          |
|------------------|-----|---------------------|-----------|----------|
| ZONE             | REV | DESCRIPTION         | DATE      | APPROVED |
| -                | A   | ORIGINAL ISSUE. GMF | 09 MAY 07 | GMF      |

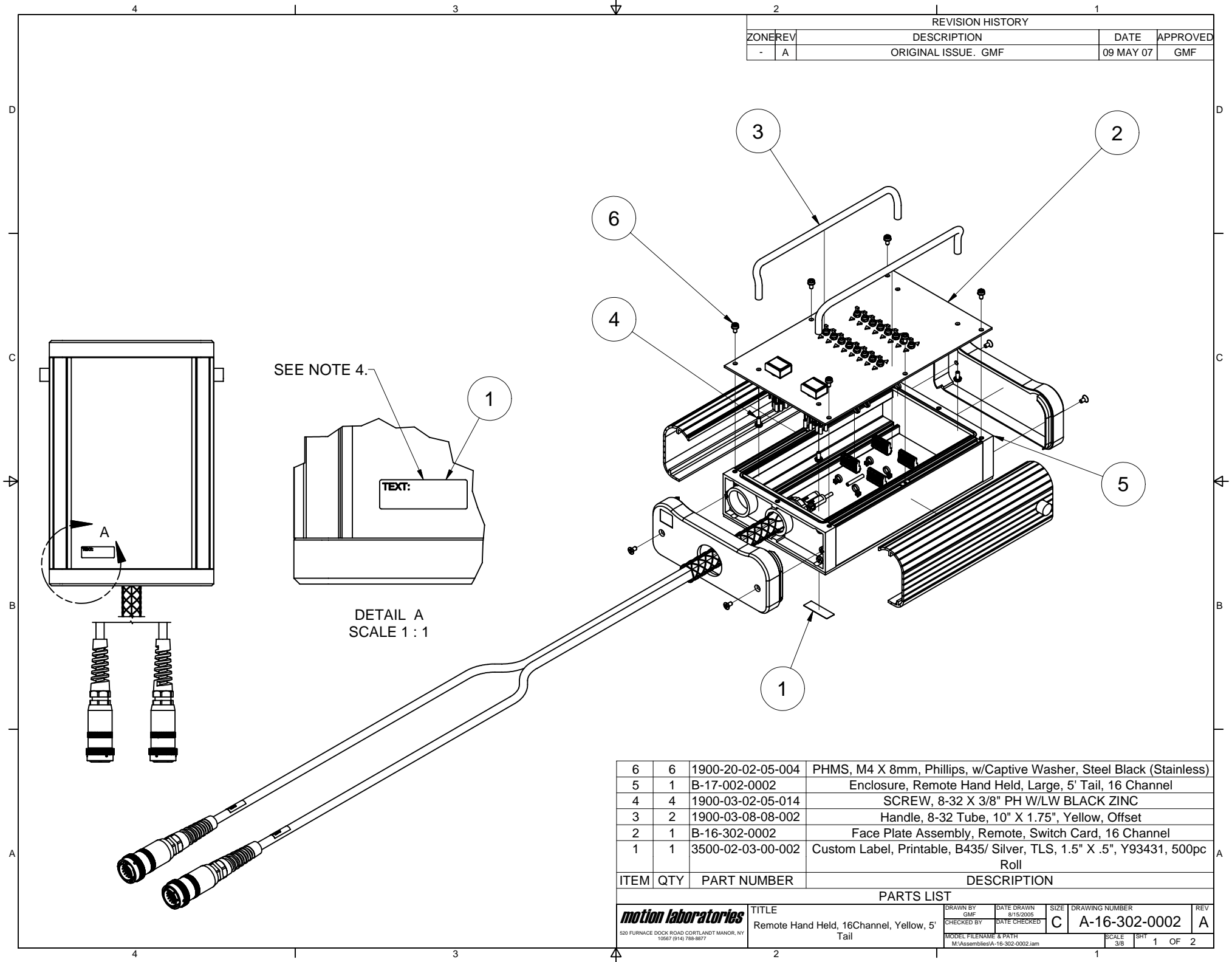

SEE NOTE 4.

DETAIL A  
SCALE 1 : 1

| ITEM | QTY | PART NUMBER       | DESCRIPTION  |
|------|-----|-------------------|--|
| 6    | 6   | 1900-20-02-05-004 | PHMS, M4 X 8mm, Phillips, w/Captive Washer, Steel Black (Stainless)        |
| 5    | 1   | B-17-002-0002     | Enclosure, Remote Hand Held, Large, 5' Tail, 16 Channel                    |
| 4    | 4   | 1900-03-02-05-014 | SCREW, 8-32 X 3/8" PH W/LW BLACK ZINC                                      |
| 3    | 2   | 1900-03-08-08-002 | Handle, 8-32 Tube, 10" X 1.75", Yellow, Offset                             |
| 2    | 1   | B-16-302-0002     | Face Plate Assembly, Remote, Switch Card, 16 Channel                       |
| 1    | 1   | 3500-02-03-00-002 | Custom Label, Printable, B435/ Silver, TLS, 1.5" X .5", Y93431, 500pc Roll |

PARTS LIST

|   |  |                                 |            |      |                |     |
|---|--|---------------------------------|------------|------|----------------|-----|
| <b>motion laboratories</b><br><small>520 FURNACE DOCK ROAD CORTLANDT MANOR, NY 10567 (914) 789-8877</small> | TITLE  | DRAWN BY                        | DATE DRAWN | SIZE | DRAWING NUMBER | REV |
|   | Remote Hand Held, 16Channel, Yellow, 5' Tail | GMF                             | 8/15/2005  | C    | A-16-302-0002  | A   |
|   | CHECKED BY                                   | DATE CHECKED                    | SCALE      | SHT  |                |     |
|   | MODEL FILENAME & PATH                        | M:\Assemblies\A-16-302-0002.lam | 3/8        | 1    | OF 2           |     |

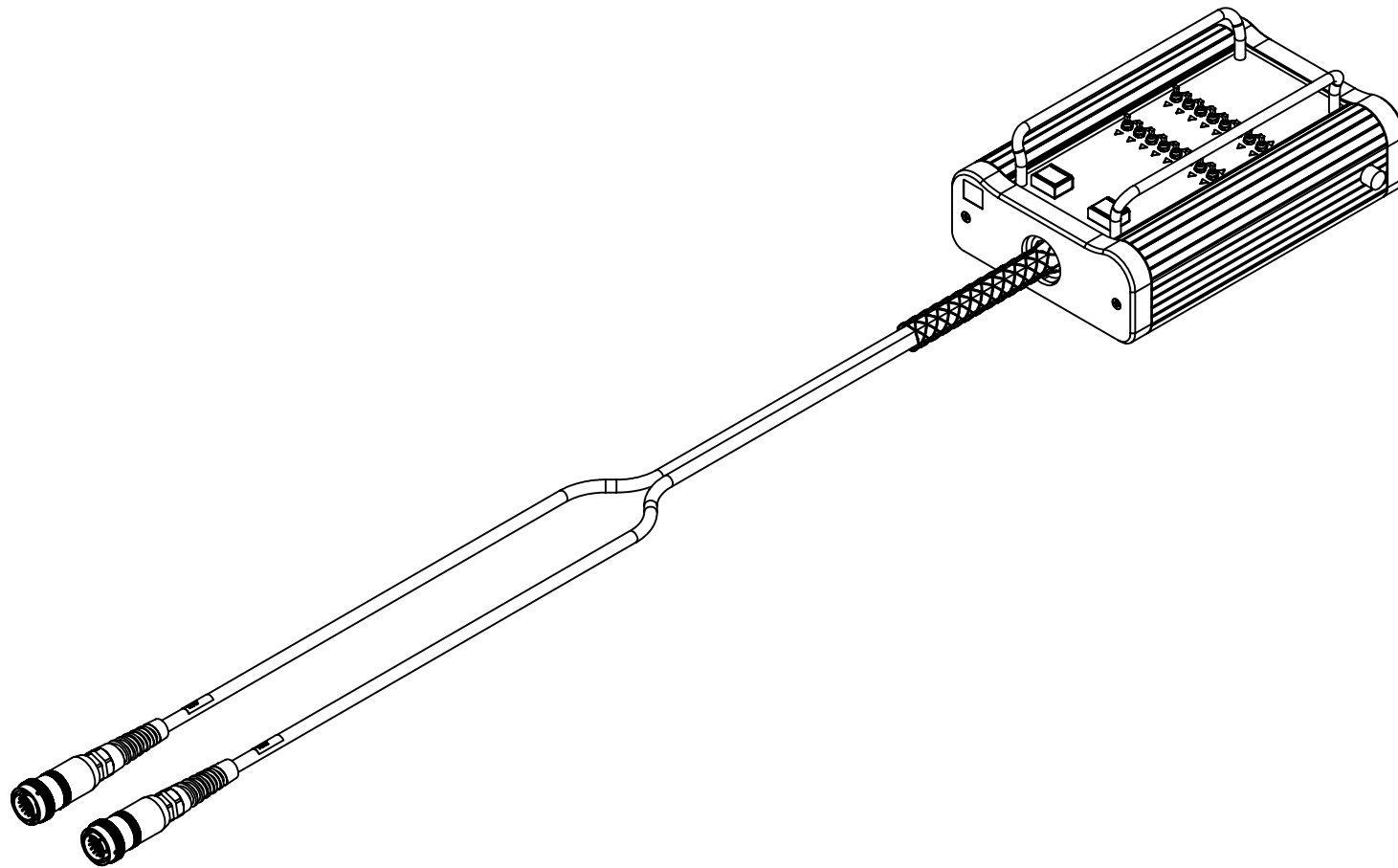

|  |   |  |                                |  |                          |  |                         |
|--|---|--|--------------------------------|--|--------------------------|--|-------------------------|
| <b><i>motion laboratories</i></b><br><small>520 FURNACE DOCK ROAD CORTLANDT MANOR, NY<br/>10567 (514) 789-8877</small> | <b>TITLE</b><br>Remote Hand Held, 16Channel, Yellow, 5'<br>Tail |  | <small>DRAWN BY</small><br>GMF | <small>DATE DRAWN</small><br>8/15/2005 | <small>SIZE</small><br>C | <small>DRAWING NUMBER</small><br>A-16-302-0002 | <small>REV</small><br>A |
|  | <small>CHECKED BY</small><br>M:\Assemblies\A-16-302-0002.iam    |  | <small>DATE CHECKED</small>    | <small>SCALE</small><br>1              |                          | <small>SHT</small><br>2 OF 2                   |                         |